

Inter Console

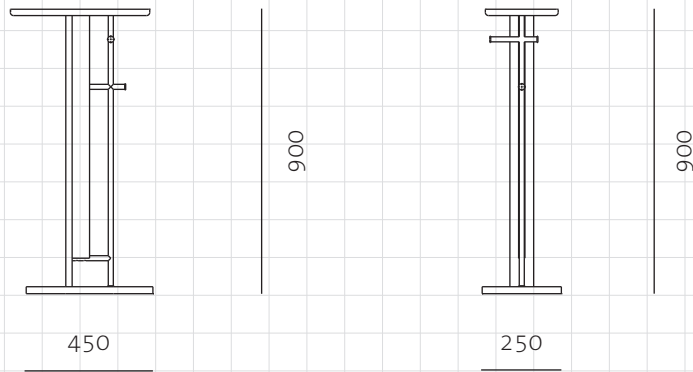

CODE

IT-T310

DIMENSIONS

W450 x D250 x H900mm

NET WEIGHT

10.0 kg

ENVIRONMENT

Indoor

MATERIALS

Solid wood frame, stainless steel oil rubbed copper, steel black powder coat matt

\*Please refer to website or contact your local representative for complete material swatches.

SHIPPING

|                    |                         |                     |                          |
|--------------------|-------------------------|---------------------|--------------------------|
| <b>Package</b>     | Assembled               |                     |                          |
| <b>Package Qty</b> | 1 pcs/box               |                     |                          |
| <b>Packaging</b>   | <b>Measurement (mm)</b> | <b>Volume (cbm)</b> | <b>Gross Weight (kg)</b> |
| <b>FCL</b>         | W515 x D315 x H985      | 0.16                | 14.88                    |
| <b>LCL/AIR</b>     | W535 x D335 x H1080     | 0.19                | 16.96                    |