

Inter Coat Hanger

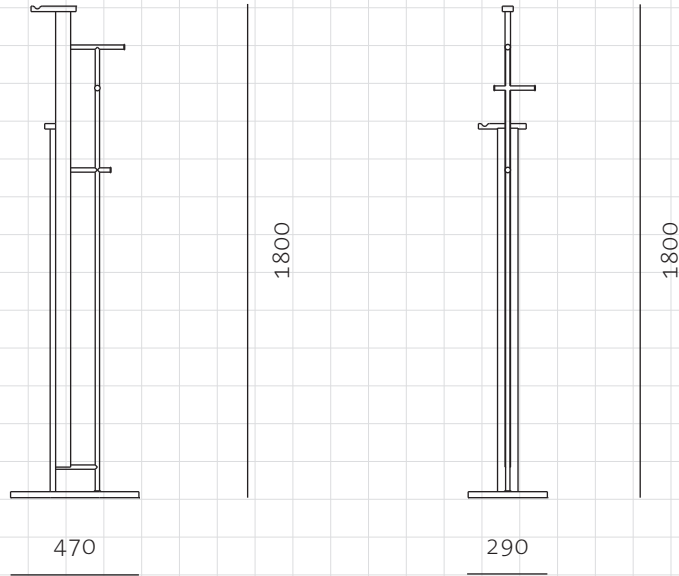

CODE
DIMENSIONS

IT-V110
W470 x D290 x H1800mm

NET WEIGHT
ENVIRONMENT
MATERIALS

12.0 kg
Indoor
Solid wood frame, stainless steel oil rubbed copper, steel black powder coat matt
*Please refer to website or contact your local representative for complete material swatches.

SHIPPING

Package	Assembled		
Package Qty	1 pcs/box		
Packaging	Measurement (mm)	Volume (cbm)	Gross Weight (kg)
FCL	W535 x D355 x H1885	0.36	25.55
LCL/AIR	W555 x D375 x H1980	0.41	27.97