

Atelier Center-Leg

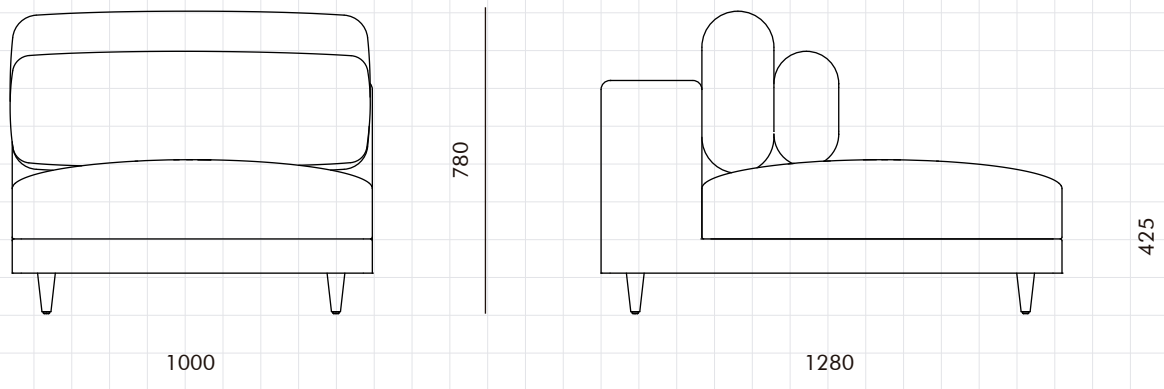

CODE

AT-S411

DIMENSIONS

W1000 x D1280 x H780mm

Seating height: 425mm

NET WEIGHT

30.0 kg

ENVIRONMENT

Indoor

MATERIALS

Solid wood and plywood frame, upholstery

\*Please refer to website or contact your local representative for complete material swatches.

SHIPPING

<b>Package</b>	Assembled		
<b>Package Qty</b>	1 pcs/box		
<b>Packaging</b>	<b>Measurement (mm)</b>	<b>Volume (cbm)</b>	<b>Gross Weight (kg)</b>
<b>FCL</b>	W1065 x D1345 x H735	1.05	39.36
<b>LCL/AIR</b>	W1085 x D1365 x H830	1.23	56.57