

Triangle Chair (1952)

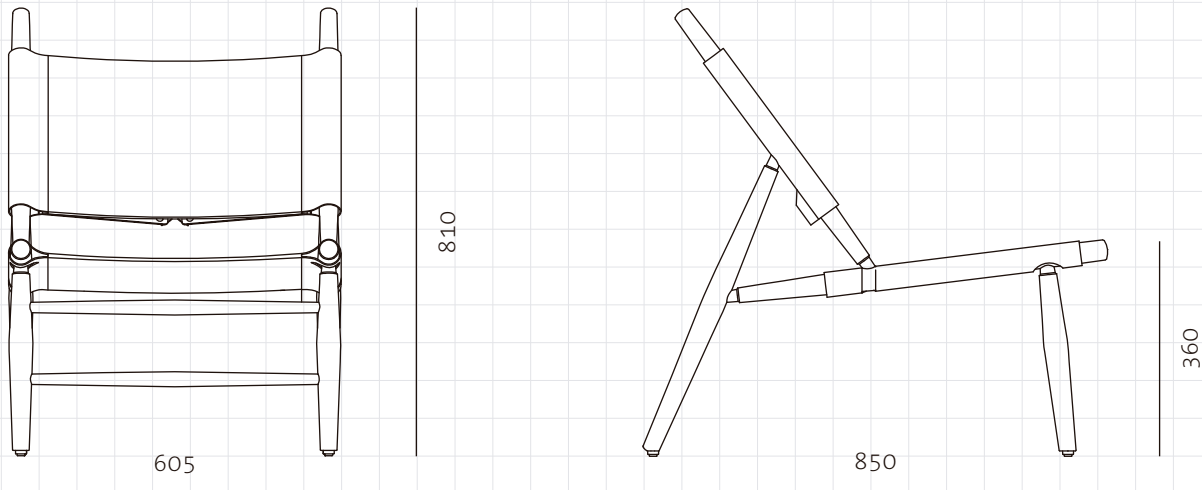

**CODE**  
**DIMENSIONS**

VW-S110  
W605 x D850 x H810mm  
Seating height: 360mm

**NET WEIGHT**  
**ENVIRONMENT**  
**MATERIALS**

5.0 kg  
Indoor  
Solid wood frame, leather/saddle leather seat and back  
\*Please refer to website or contact your local representative for complete material swatches.

**SHIPPING**

<b>Package</b>	Assembled		
<b>Package Qty</b>	1 pcs/box		
<b>Packaging</b>	<b>Measurement (mm)</b>	<b>Volume (cbm)</b>	<b>Gross Weight (kg)</b>
<b>FCL</b>	W670 x D915 x H895	0.55	12.08
<b>LCL/AIR</b>	W690 x D935 x H990	0.64	19.58