

**Utility Lounge Chair Two Seater**

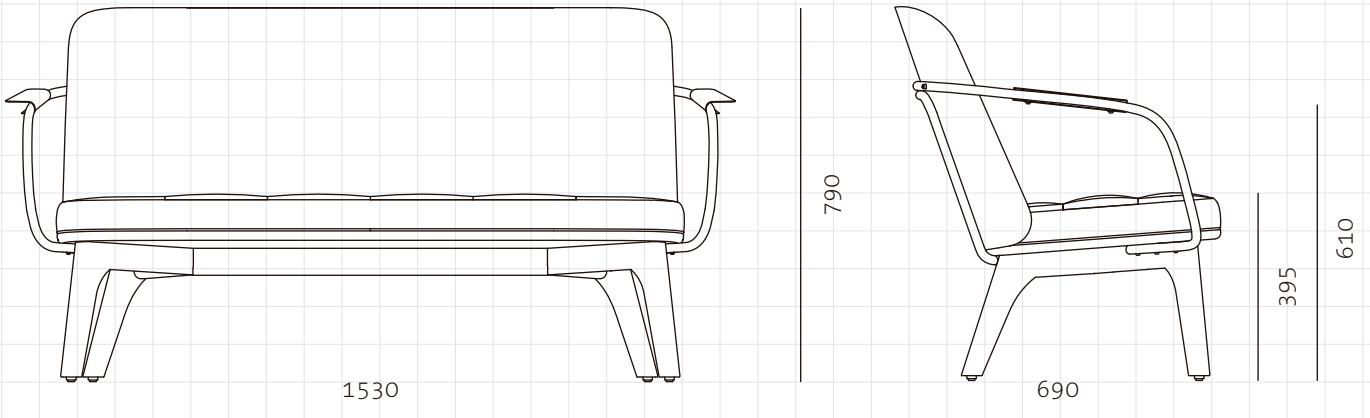

**CODE**

UT-S121

**DIMENSIONS**

W1545 x D690 x H790mm

Seating height: 395mm

**NET WEIGHT**

34.5 kg

**ENVIRONMENT**

Indoor

**MATERIALS**

Solid wood legs, Plywood panels, Steel hairline aged gold, Upholstery

\*Please refer to website or contact your local representative for complete material swatches.

**SHIPPING**

<b>Package</b>	Assembled		
<b>Package Qty</b>	1 pcs/box		
<b>Packaging</b>	<b>Measurement (mm)</b>	<b>Volume (cbm)</b>	<b>Gross Weight (kg)</b>
<b>FCL</b>	W1630 x D775 x H895	1.13	45.04
<b>LCL/AIR</b>	W1650 x D795 x H990	1.30	60.28