

Ming Aluminium Café Table

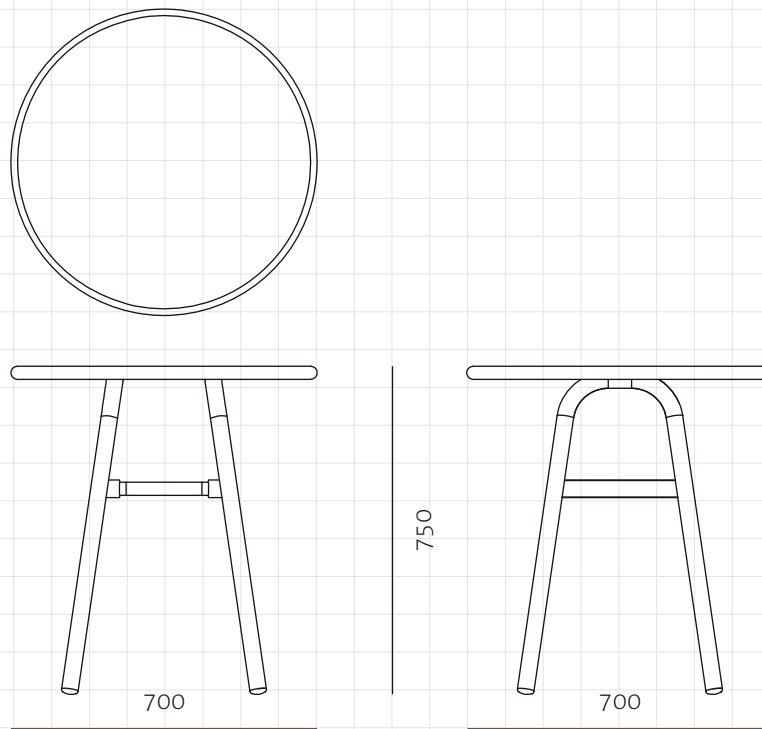

CODE MI-T310
DIMENSIONS C700 x H750mm

NET WEIGHT 9.0 kg
ENVIRONMENT Outdoor

MATERIALS Aluminium, available in black/grey/white
*Please refer to website or contact your local representative for complete material swatches.

SHIPPING	Package	Knock Down		
	Package Qty	1 pcs/box		
	Packaging	Measurement (mm)	Volume (cbm)	Gross Weight (kg)
FCL		W805 x D750 x H155	0.09	11.17
LCL/AIR		W825 x D770 x H175	0.11	18.55