

Mandarin Lounge Chair

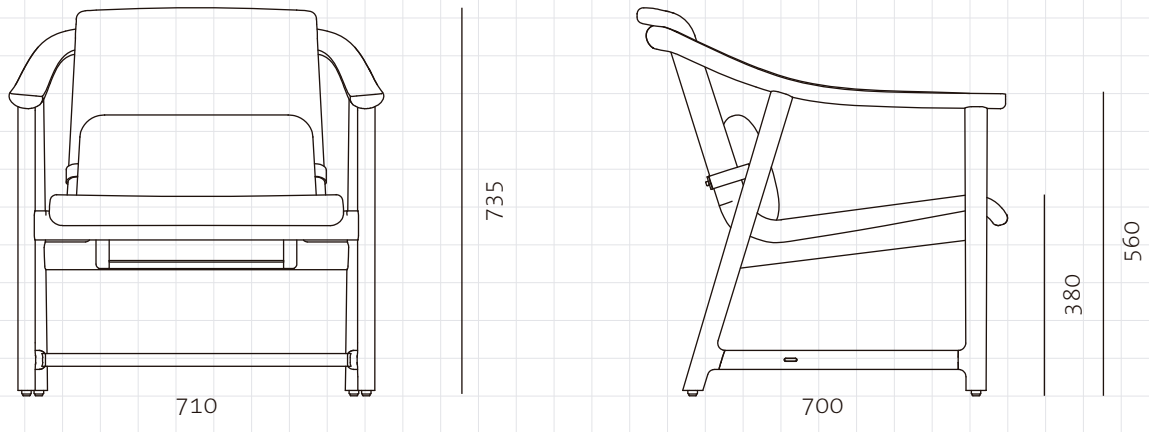

CODE

MA-S111

DIMENSIONS

W710 x D700 x H735mm

NET WEIGHT

Seating height: 380mm

ENVIRONMENT

12.8 kg

MATERIALS

Indoor

Solid wood frame, stainless steel hairline gold, upholstered seat shell

*Please refer to website or contact your local representative for complete material swatches.

SHIPPING

Package	Assembled		
Package Qty	1 pcs/box		
Packaging	Measurement (mm)	Volume (cbm)	Gross Weight (kg)
FCL	W775 x D765 x H820	0.49	19.12
LCL/AIR	W795 x D785 x H915	0.57	26.37