

Mandarin Dining Chair

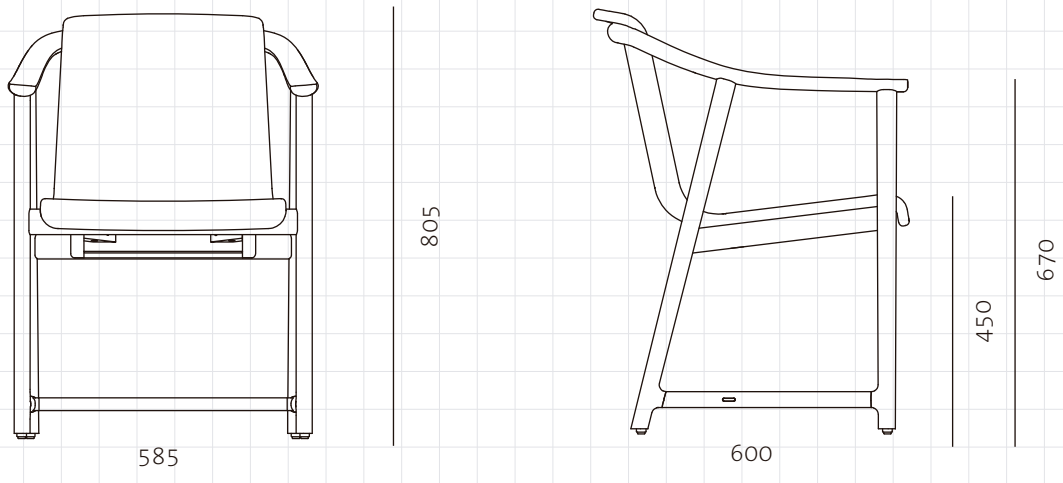

CODE
DIMENSIONS

MA-S211
W585 x D600 x H805mm
Seating height: 450mm

NET WEIGHT
ENVIRONMENT
MATERIALS

9.7 kg
Indoor
Solid wood frame, stainless steel hairline gold, upholstered seat shell
*Please refer to website or contact your local representative for complete material swatches.

SHIPPING

Package	Assembled		
Package Qty	1 pcs/box		
Packaging	Measurement (mm)	Volume (cbm)	Gross Weight (kg)
FCL	W701 x D676 x H866	0.41	15.74
LCL/AIR	W741 x D716 x H956	0.51	21.91