

James Bar Cart

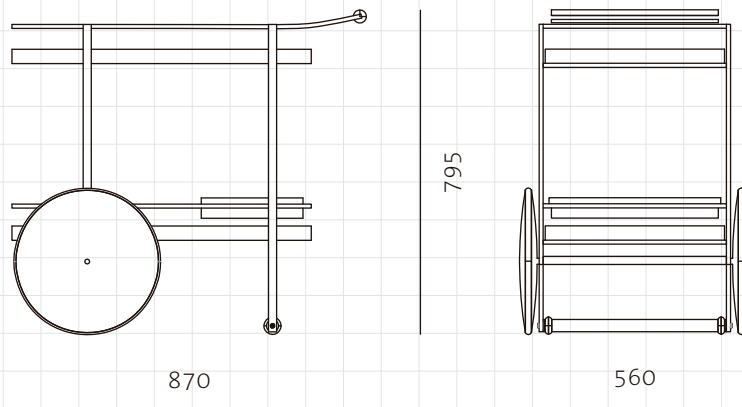

CODE

JA-CA110

DIMENSIONS

W870 x D560 x H795mm

NET WEIGHT

27.5 kg

ENVIRONMENT

Indoor

MATERIALS

Veneer laminate panels, steel black powder coat sand brust with soft touch finish, solid wood handle

*Please refer to website or contact your local representative for complete material swatches.

SHIPPING

Package	Assembled		
Package Qty	1 pcs/box		
Packaging	Measurement (mm)	Volume (cbm)	Gross Weight (kg)
FCL	W935 x D625 x H880	0.51	34.33
LCL/AIR	W955 x D645 x H975	0.60	41.49